

## Кинематический анализ механизма (7 звеньев)

Плоский многозвенный механизм с одной степенью свободы приводится в движение кривошипом, который вращается против часовой стрелки с постоянной угловой скоростью. Найти скорости всех шарниров механизма (в см/с) и ускорения трех заданных шарниров (в м/с<sup>2</sup>). Размеры даны в сантиметрах.

Кирсанов М.Н. **Решебник. Теоретическая механика**/Под ред. А. И. Кириллова. – М.: ФИЗМАТЛИТ, 2008. – 384 с. (с.158.)

### Задача К9.1.

10

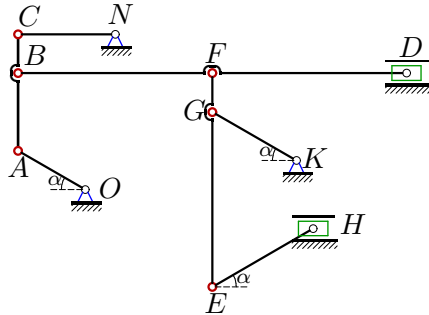

$\omega_{NC} = 1$  рад/с,  $\alpha = 30^\circ$ ,  
 $AB = 20$ ,  $BC = 10$ ,  
 $BF = 50$ ,  $FD = 50$ ,  
 $NC = 25$ ,  $EH = 30$ ,  
 $FE = 55$ ,  $FG = 10$ ,  
 $OA = 20$ ,  $KG = 25$ .  
 $a_A$ ,  $a_B$ ,  $a_C$  - ?

### Задача К9.2.

10

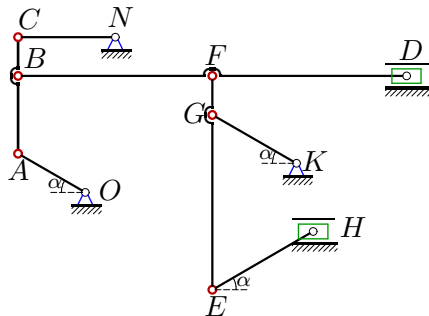

$\omega_{NC} = 2$  рад/с,  $\alpha = 30^\circ$ ,  
 $AB = 20$ ,  $BC = 10$ ,  
 $BF = 50$ ,  $FD = 50$ ,  
 $NC = 25$ ,  $EH = 30$ ,  
 $FE = 55$ ,  $FG = 10$ ,  
 $OA = 20$ ,  $KG = 25$ .  
 $a_A$ ,  $a_B$ ,  $a_C$  - ?

### Задача К9.3.

10

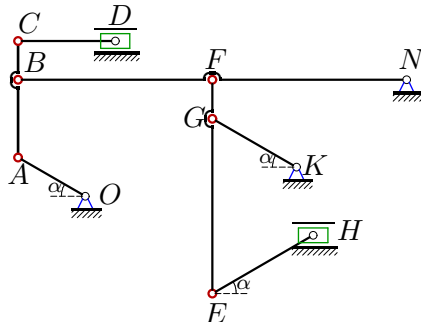

$\omega_{KG} = 4$  рад/с,  $\alpha = 30^\circ$ ,  
 $AB = 20$ ,  $BC = 10$ ,  
 $BF = 50$ ,  $NF = 50$ ,  
 $CD = 25$ ,  $EH = 30$ ,  
 $FG = 10$ ,  $GE = 45$ ,  
 $OA = 20$ ,  $KG = 25$ .  
 $a_G$ ,  $a_F$ ,  $a_E$  - ?

### Задача К9.4.

10

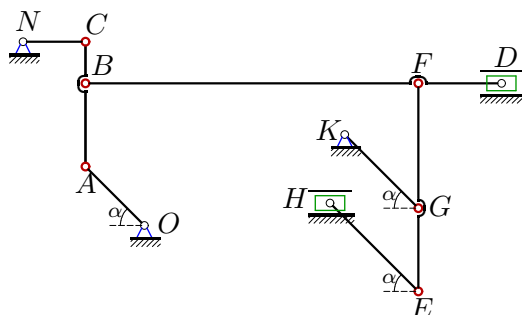

$\omega_{NC} = 4$  рад/с,  $\alpha = 45^\circ$ ,  
 $AB = 20$ ,  $BC = 10$ ,  
 $BF = 80$ ,  $FD = 20$ ,  
 $NC = 15$ ,  $EH = 30$ ,  
 $FE = 50$ ,  $FG = 30$ ,  
 $OA = 20$ ,  $KG = 25$ .  
 $a_A$ ,  $a_B$ ,  $a_C$  - ?

**Задача K9.5.**

10

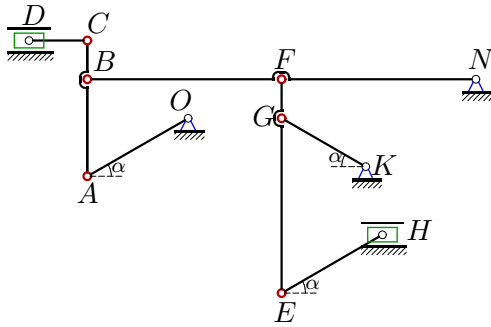

$\omega_{OA} = 1 \text{ рад/с}, \alpha = 30^\circ,$   
 $AB = 25, BC = 10,$   
 $BF = 50, NF = 50,$   
 $CD = 15, EH = 30,$   
 $FG = 10, GE = 45,$   
 $OA = 30, KG = 25.$   
 $a_A, a_B, a_C - ?$

**Задача K9.6.**

10

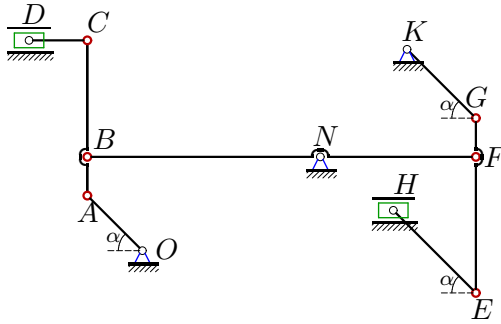

$\omega_{BF} = 4 \text{ рад/с}, \alpha = 45^\circ,$   
 $AB = 10, BC = 30,$   
 $NB = 60, NF = 40,$   
 $CD = 15, EH = 30,$   
 $FE = 35, FG = 10,$   
 $OA = 20, KG = 25.$   
 $a_A, a_B, a_C - ?$

**Задача K9.7.**

10

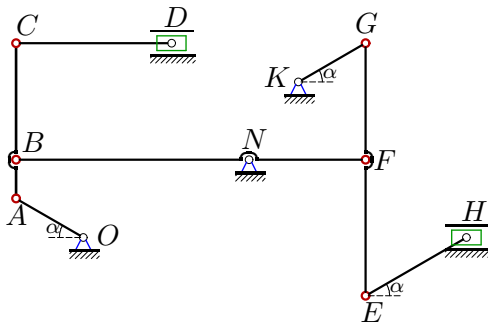

$\omega_{BF} = 4 \text{ рад/с}, \alpha = 30^\circ,$   
 $AB = 10, BC = 30,$   
 $NB = 60, NF = 30,$   
 $CD = 40, EH = 30,$   
 $FE = 35, FG = 30,$   
 $OA = 20, KG = 20.$   
 $a_A, a_B, a_C - ?$

**Задача K9.8.**

10

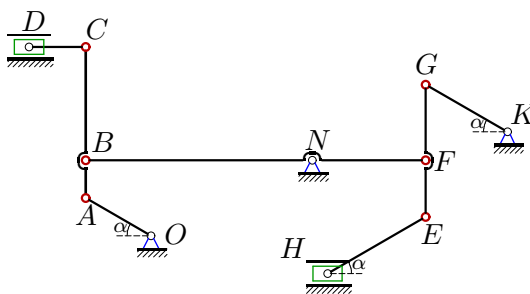

$\omega_{BF} = 4 \text{ рад/с}, \alpha = 30^\circ,$   
 $AB = 10, BC = 30,$   
 $NB = 60, NF = 30,$   
 $CD = 15, EH = 30,$   
 $FE = 15, FG = 20,$   
 $OA = 20, KG = 25.$   
 $a_A, a_B, a_C - ?$

**Задача K9.9.**

10

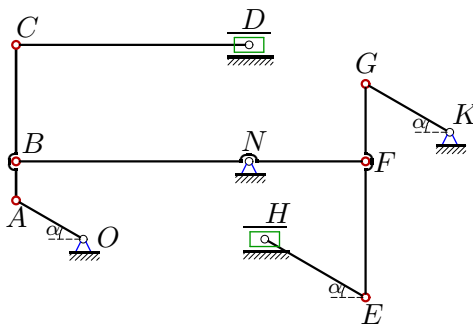

$\omega_{KG} = 3 \text{ рад/с}, \alpha = 30^\circ,$   
 $AB = 10, BC = 30,$   
 $NB = 60, NF = 30,$   
 $CD = 60, EH = 30,$   
 $FE = 35, FG = 20,$   
 $OA = 20, KG = 25.$   
 $a_G, a_F, a_E - ?$

Задача K9.10.

10

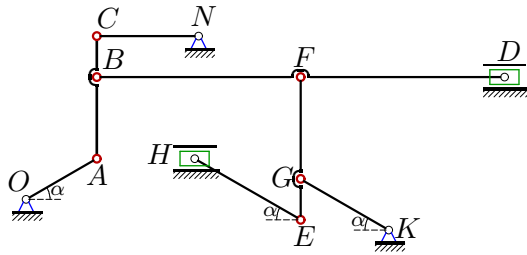

$\omega_{OA} = 4$  рад/с,  $\alpha = 30^\circ$ ,  
 $AB = 20$ ,  $BC = 10$ ,  
 $BF = 50$ ,  $FD = 50$ ,  
 $NC = 25$ ,  $EH = 30$ ,  
 $FE = 35$ ,  $FG = 25$ ,  
 $OA = 20$ ,  $KG = 25$ .  
 $a_A$ ,  $a_B$ ,  $a_C$  - ?

Задача K9.11.

10

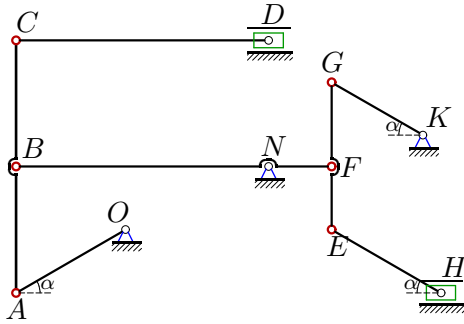

$\omega_{OA} = 3$  рад/с,  $\alpha = 30^\circ$ ,  
 $AB = 30$ ,  $BC = 30$ ,  
 $NB = 60$ ,  $NF = 15$ ,  
 $CD = 60$ ,  $EH = 30$ ,  
 $FE = 15$ ,  $FG = 20$ ,  
 $OA = 30$ ,  $KG = 25$ .  
 $a_A$ ,  $a_B$ ,  $a_C$  - ?

Задача K9.12.

10

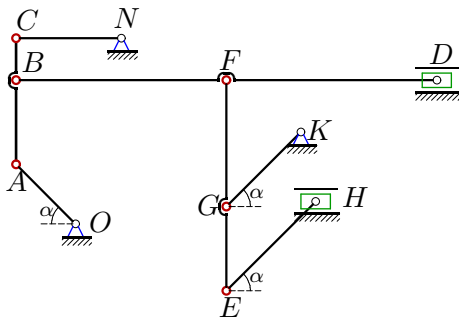

$\omega_{OA} = 1$  рад/с,  $\alpha = 45^\circ$ ,  
 $AB = 20$ ,  $BC = 10$ ,  
 $BF = 50$ ,  $FD = 50$ ,  
 $NC = 25$ ,  $EH = 30$ ,  
 $FE = 50$ ,  $FG = 30$ ,  
 $OA = 20$ ,  $KG = 25$ .  
 $a_A$ ,  $a_B$ ,  $a_C$  - ?

Задача K9.13.

10

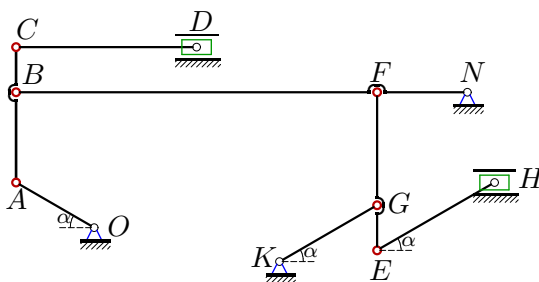

$\omega_{OA} = 1$  рад/с,  $\alpha = 30^\circ$ ,  
 $AB = 20$ ,  $BC = 10$ ,  
 $BF = 80$ ,  $NF = 20$ ,  
 $CD = 40$ ,  $EH = 30$ ,  
 $FG = 25$ ,  $GE = 10$ ,  
 $OA = 20$ ,  $KG = 25$ .  
 $a_A$ ,  $a_B$ ,  $a_C$  - ?

Задача K9.14.

10

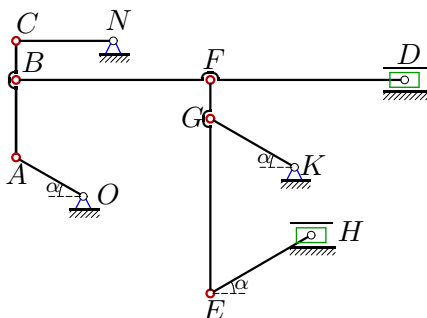

$\omega_{OA} = 2$  рад/с,  $\alpha = 30^\circ$ ,  
 $AB = 20$ ,  $BC = 10$ ,  
 $BF = 50$ ,  $FD = 50$ ,  
 $NC = 25$ ,  $EH = 30$ ,  
 $FE = 55$ ,  $FG = 10$ ,  
 $OA = 20$ ,  $KG = 25$ .  
 $a_A$ ,  $a_B$ ,  $a_C$  - ?

Задача K9.15.

10

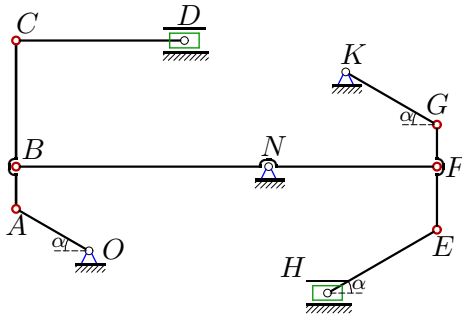

$\omega_{KG} = 3 \text{ рад/с}, \alpha = 30^\circ,$   
 $AB = 10, BC = 30,$   
 $NB = 60, NF = 40,$   
 $CD = 40, EH = 30,$   
 $FE = 15, FG = 10,$   
 $OA = 20, KG = 25.$   
 $a_G, a_F, a_E - ?$

Задача K9.16.

10

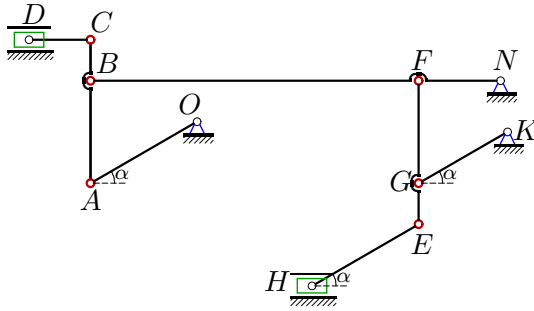

$\omega_{KG} = 4 \text{ рад/с}, \alpha = 30^\circ,$   
 $AB = 25, BC = 10,$   
 $BF = 80, NF = 20,$   
 $CD = 15, EH = 30,$   
 $FG = 25, GE = 10,$   
 $OA = 30, KG = 25.$   
 $a_G, a_F, a_E - ?$

Задача K9.17.

10

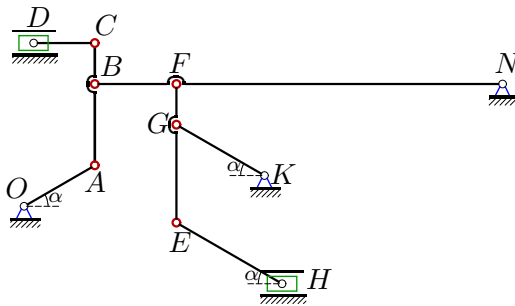

$\omega_{NB} = 2 \text{ рад/с}, \alpha = 30^\circ,$   
 $AB = 20, BC = 10,$   
 $BF = 20, NF = 80,$   
 $CD = 15, EH = 30,$   
 $FG = 10, GE = 24,$   
 $OA = 20, KG = 25.$   
 $a_A, a_B, a_C - ?$

Задача K9.18.

10

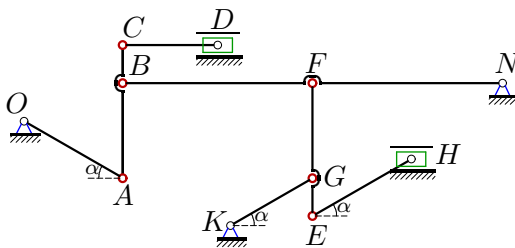

$\omega_{KG} = 3 \text{ рад/с}, \alpha = 30^\circ,$   
 $AB = 25, BC = 10,$   
 $BF = 50, NF = 50,$   
 $CD = 25, EH = 30,$   
 $FG = 25, GE = 10,$   
 $OA = 30, KG = 25.$   
 $a_G, a_F, a_E - ?$

Задача K9.19.

10

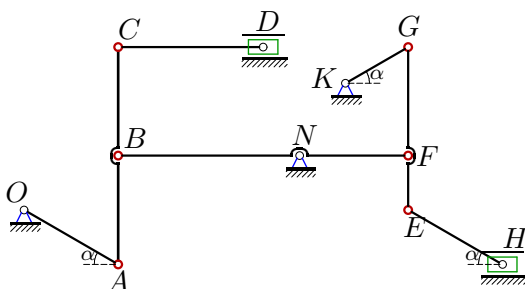

$\omega_{BF} = 3 \text{ рад/с}, \alpha = 30^\circ,$   
 $AB = 30, BC = 30,$   
 $NB = 50, NF = 30,$   
 $CD = 40, EH = 30,$   
 $FE = 15, FG = 30,$   
 $OA = 30, KG = 20.$   
 $a_A, a_B, a_C - ?$

Задача K9.20.

10

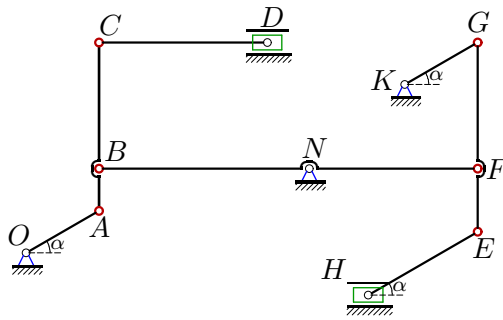

$\omega_{BF} = 1$  рад/с,  $\alpha = 30^\circ$ ,  
 $AB = 10$ ,  $BC = 30$ ,  
 $NB = 50$ ,  $NF = 40$ ,  
 $CD = 40$ ,  $EH = 30$ ,  
 $FE = 15$ ,  $FG = 30$ ,  
 $OA = 20$ ,  $KG = 20$ .  
 $a_A$ ,  $a_B$ ,  $a_C$  - ?

Задача K9.21.

10

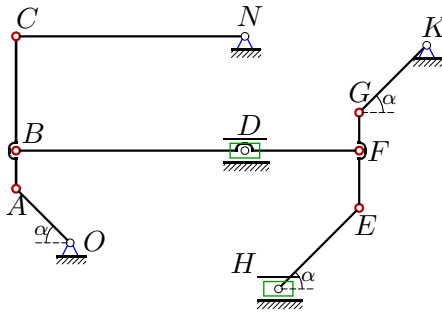

$\omega_{OA} = 2$  рад/с,  $\alpha = 45^\circ$ ,  
 $AB = 10$ ,  $BC = 30$ ,  
 $DB = 60$ ,  $DF = 30$ ,  
 $NC = 60$ ,  $EH = 30$ ,  
 $FE = 15$ ,  $FG = 10$ ,  
 $OA = 20$ ,  $KG = 25$ .  
 $a_A$ ,  $a_B$ ,  $a_C$  - ?

Задача K9.22.

10

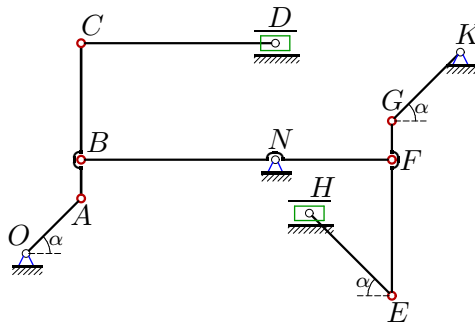

$\omega_{OA} = 2$  рад/с,  $\alpha = 45^\circ$ ,  
 $AB = 10$ ,  $BC = 30$ ,  
 $NB = 50$ ,  $NF = 30$ ,  
 $CD = 50$ ,  $EH = 30$ ,  
 $FE = 35$ ,  $FG = 10$ ,  
 $OA = 20$ ,  $KG = 25$ .  
 $a_A$ ,  $a_B$ ,  $a_C$  - ?

Задача K9.23.

10

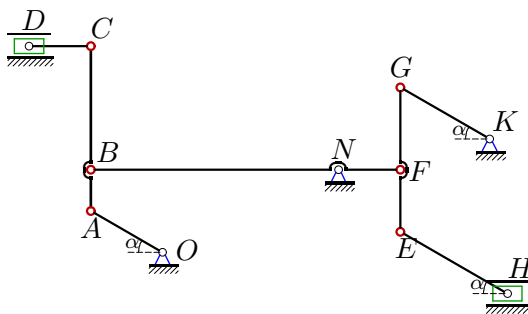

$\omega_{BF} = 4$  рад/с,  $\alpha = 30^\circ$ ,  
 $AB = 10$ ,  $BC = 30$ ,  
 $NB = 60$ ,  $NF = 15$ ,  
 $CD = 15$ ,  $EH = 30$ ,  
 $FE = 15$ ,  $FG = 20$ ,  
 $OA = 20$ ,  $KG = 25$ .  
 $a_A$ ,  $a_B$ ,  $a_C$  - ?

Задача K9.24.

10

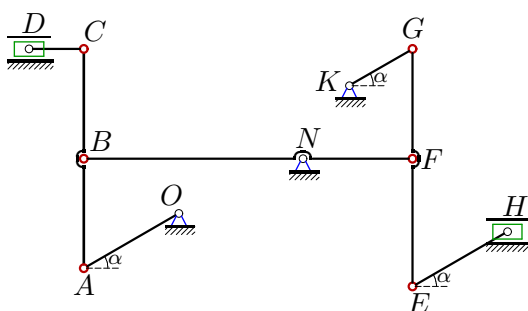

$\omega_{OA} = 1$  рад/с,  $\alpha = 30^\circ$ ,  
 $AB = 30$ ,  $BC = 30$ ,  
 $NB = 60$ ,  $NF = 30$ ,  
 $CD = 15$ ,  $EH = 30$ ,  
 $FE = 35$ ,  $FG = 30$ ,  
 $OA = 30$ ,  $KG = 20$ .  
 $a_A$ ,  $a_B$ ,  $a_C$  - ?

**Задача K9.25.**

10

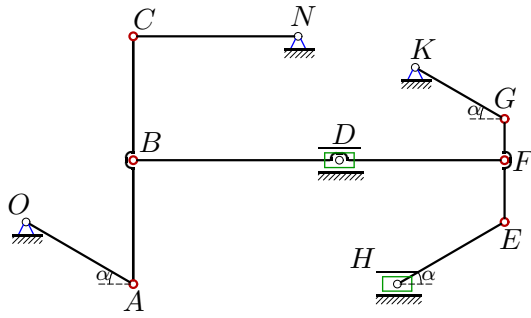

$\omega_{NC} = 1$  рад/с,  $\alpha = 30^\circ$ ,  
 $AB = 30$ ,  $BC = 30$ ,  
 $DB = 50$ ,  $DF = 40$ ,  
 $NC = 40$ ,  $EH = 30$ ,  
 $FE = 15$ ,  $FG = 10$ ,  
 $OA = 30$ ,  $KG = 25$ .  
 $a_A$ ,  $a_B$ ,  $a_C$  - ?

**Задача K9.26.**

10

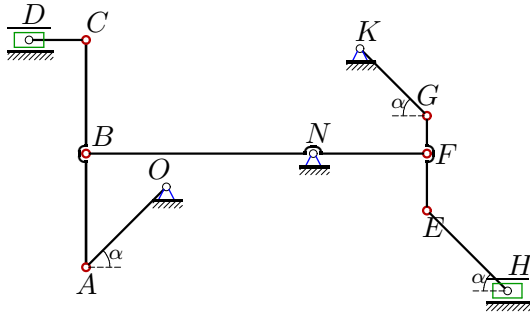

$\omega_{OA} = 1$  рад/с,  $\alpha = 45^\circ$ ,  
 $AB = 30$ ,  $BC = 30$ ,  
 $NB = 60$ ,  $NF = 30$ ,  
 $CD = 15$ ,  $EH = 30$ ,  
 $FE = 15$ ,  $FG = 10$ ,  
 $OA = 30$ ,  $KG = 25$ .  
 $a_A$ ,  $a_B$ ,  $a_C$  - ?

**Задача K9.27.**

10

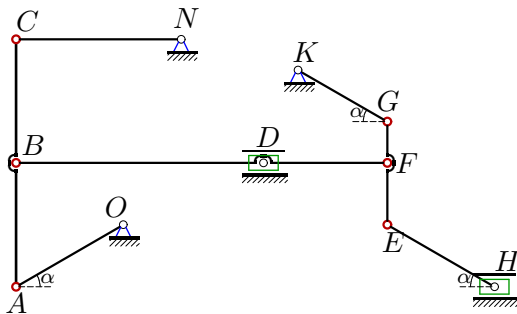

$\omega_{NC} = 4$  рад/с,  $\alpha = 30^\circ$ ,  
 $AB = 30$ ,  $BC = 30$ ,  
 $DB = 60$ ,  $DF = 30$ ,  
 $NC = 40$ ,  $EH = 30$ ,  
 $FE = 15$ ,  $FG = 10$ ,  
 $OA = 30$ ,  $KG = 25$ .  
 $a_A$ ,  $a_B$ ,  $a_C$  - ?

**Задача K9.28.**

10

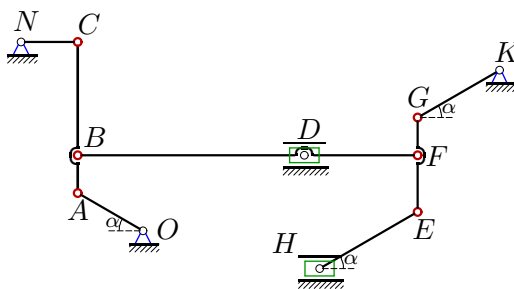

$\omega_{NC} = 3$  рад/с,  $\alpha = 30^\circ$ ,  
 $AB = 10$ ,  $BC = 30$ ,  
 $DB = 60$ ,  $DF = 30$ ,  
 $NC = 15$ ,  $EH = 30$ ,  
 $FE = 15$ ,  $FG = 10$ ,  
 $OA = 20$ ,  $KG = 25$ .  
 $a_A$ ,  $a_B$ ,  $a_C$  - ?

**Задача K9.29.**

10

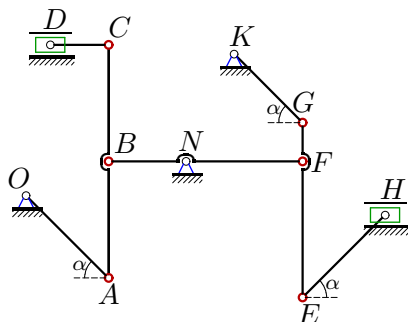

$\omega_{OA} = 4$  рад/с,  $\alpha = 45^\circ$ ,  
 $AB = 30$ ,  $BC = 30$ ,  
 $NB = 20$ ,  $NF = 30$ ,  
 $CD = 15$ ,  $EH = 30$ ,  
 $FE = 35$ ,  $FG = 10$ ,  
 $OA = 30$ ,  $KG = 25$ .  
 $a_A$ ,  $a_B$ ,  $a_C$  - ?

**Задача К9.30.**

10

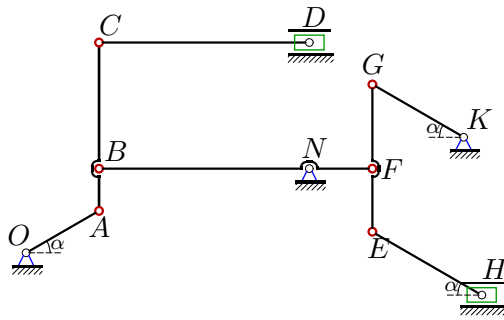

$\omega_{KG} = 1 \text{ рад/с}, \alpha = 30^\circ,$   
 $AB = 10, BC = 30,$   
 $NB = 50, NF = 15,$   
 $CD = 50, EH = 30,$   
 $FE = 15, FG = 20,$   
 $OA = 20, KG = 25.$   
 $a_G, a_F, a_E - ?$

**К9 Ответы.**  
**Кинематический анализ механизма (7 звеньев)**

04.04.2012

№	$v_A$	$v_B$	$v_C$	$v_D$	$v_E$	$v_F$	$v_G$	$v_H$
1	28.868	25.459	25.000	4.811	21.949	13.394	14.434	25.259
2	57.735	50.918	50.000	9.623	43.899	26.788	28.868	50.518
3	200.000	173.205	180.278	50.000	288.314	86.603	100.000	325.000
4	84.853	63.246	60.000	20.000	13.728	23.324	16.971	5.333
5	30.000	25.981	26.665	6.000	43.247	12.990	15.000	48.750
6	339.411	240.000	758.947	720.000	582.409	160.000	226.274	720.000
7	277.128	240.000	480.000	415.692	144.684	120.000	138.564	150.111
8	277.128	240.000	480.000	415.692	130.767	120.000	138.564	17.321
9	150.000	129.904	259.808	225.000	92.333	64.952	75.000	103.125
10	80.000	70.553	69.282	13.333	48.074	37.118	40.000	13.333
11	90.000	77.942	90.000	45.000	21.234	19.486	22.500	19.688
12	20.000	14.907	14.142	4.714	16.518	8.498	10.000	7.857
13	20.000	17.321	18.028	5.000	4.454	3.464	4.000	0.800
14	40.000	35.277	34.641	6.667	30.414	18.559	20.000	35.000
15	112.500	97.428	194.856	168.750	85.923	64.952	75.000	18.750
16	500.000	433.013	444.410	100.000	111.355	86.603	100.000	20.000
17	230.940	200.000	208.167	57.735	352.485	160.000	184.752	221.703
18	150.000	129.904	133.323	30.000	83.516	64.952	75.000	15.000
19	173.205	150.000	173.205	86.603	93.675	90.000	103.923	25.981
20	57.735	50.000	100.000	86.603	41.633	40.000	46.188	34.641
21	40.000	35.355	28.284	21.213	34.821	25.495	20.000	17.678
22	40.000	28.284	89.443	84.853	61.774	16.971	24.000	42.426
23	277.128	240.000	480.000	415.692	65.383	60.000	69.282	60.622
24	30.000	25.981	30.000	15.000	15.662	12.990	15.000	16.250
25	46.188	41.633	40.000	11.547	65.003	34.020	36.950	38.105
26	30.000	21.213	30.000	21.213	19.121	10.607	15.000	26.517
27	184.752	166.533	160.000	46.188	92.376	92.376	92.376	0.000
28	51.962	49.038	45.000	19.486	36.886	29.765	25.981	16.238
29	120.000	84.853	120.000	84.853	463.303	127.279	180.000	318.198
30	83.333	72.169	144.338	125.000	23.593	21.651	25.000	21.875

№	$\omega_{OA}$	$\omega_{CA}$	$\omega_{CD}$	$\omega_{BF}$	$\omega_{FE}$	$\omega_{KG}$	$\omega_{EH}$	$\omega_{NC}$	$a_A$	$a_B$	$a_C$	$a_E$	$a_F$	$a_G$
1	1.443	-0.481	-	0.250	-0.241	0.577	0.481	1.000	0.526	0.341	0.250	-	-	-
2	2.887	-0.962	-	0.500	-0.481	1.155	0.962	2.000	2.103	1.365	1.000	-	-	-
3	10.000	-5.000	6.928	1.732	-5.000	4.000	3.333	-	-	-	-	15.392	4.743	4.000
4	-4.243	2.000	-	-0.600	-0.267	0.679	0.566	4.000	6.405	0.638	2.400	-	-	-
5	1.000	0.600	-1.732	0.260	-0.750	0.600	0.500	-	0.300	0.090	0.026	-	-	-
6	16.971	-24.000	-16.000	4.000	-16.000	9.051	7.542	-	150.516	9.600	416.331	-	-	-
7	13.856	-13.856	6.000	4.000	2.309	6.928	-4.619	-	58.657	9.600	140.251	-	-	-
8	13.856	-13.856	-16.000	4.000	-3.464	-5.543	4.619	-	58.657	9.600	140.251	-	-	-
9	-7.500	7.500	-2.165	-2.165	1.875	3.000	-2.500	-	-	-	-	7.322	1.468	2.250
10	4.000	-1.333	-	-0.693	1.333	-1.600	1.333	-2.771	3.200	1.988	2.870	-	-	-
11	3.000	1.500	1.299	1.299	-0.563	-0.900	-0.750	-	2.700	1.217	0.313	-	-	-
12	1.000	-0.471	-	0.141	0.393	0.400	0.333	0.566	0.200	0.211	0.223	-	-	-
13	1.000	-0.500	0.433	0.173	0.080	-0.160	0.133	-	0.200	0.153	0.180	-	-	-
14	2.000	-0.667	-	0.346	-0.333	0.800	0.667	1.386	0.800	0.737	0.718	-	-	-
15	5.625	-5.625	2.436	1.624	-3.750	3.000	2.500	-	-	-	-	4.649	2.742	2.250
16	16.667	10.000	-28.868	4.330	2.000	4.000	-3.333	-	-	-	-	4.121	3.881	4.000
17	-11.547	5.774	-13.333	2.000	-9.238	7.390	6.158	-	35.277	4.000	23.558	-	-	-
18	5.000	3.000	-5.196	-1.299	-1.500	3.000	-2.500	-	-	-	-	3.195	1.887	2.250
19	-5.774	-2.887	3.750	3.000	1.732	5.196	-3.464	-	10.408	4.500	19.267	-	-	-
20	-2.887	2.887	1.250	1.000	0.770	2.309	1.540	-	2.546	0.500	9.550	-	-	-
21	2.000	-0.707	-	0.471	-0.707	-0.800	0.667	0.471	0.800	0.767	0.777	-	-	-
22	2.000	-2.828	-0.566	-0.566	-1.697	0.960	-0.800	-	0.800	1.375	4.432	-	-	-
23	13.856	-13.856	-16.000	4.000	-1.732	-2.771	-2.309	-	58.657	9.600	140.251	-	-	-
24	1.000	0.500	-1.732	0.433	0.250	0.750	-0.500	-	0.300	0.135	0.035	-	-	-
25	-1.540	-0.385	-	0.800	-3.002	1.478	1.232	1.000	0.775	0.190	0.400	-	-	-
26	1.000	0.707	-1.414	0.354	-1.061	0.600	-0.500	-	0.300	0.097	0.108	-	-	-
27	6.158	1.540	-	2.667	0.000	3.695	-3.079	4.000	12.399	9.385	6.400	-	-	-
28	-2.598	0.650	-	-0.750	0.650	1.039	-0.866	3.000	1.665	0.914	1.350	-	-	-
29	4.000	2.828	5.657	-4.243	12.728	-7.200	6.000	-	4.800	3.735	10.687	-	-	-
30	4.167	-4.167	-1.443	-1.443	0.625	1.000	0.833	-	-	-	-	0.709	0.316	0.250