

## Кинематический анализ механизма (7 звеньев)

Плоский многосвязный механизм с одной степенью свободы приводится в движение кривошипом, который вращается против часовой стрелки с постоянной угловой скоростью. Найти скорости всех шарниров механизма (в см/с) и ускорения трех заданных шарниров (в м/с<sup>2</sup>). Размеры даны в сантиметрах.

Кирсанов М.Н. **Решебник. Теоретическая механика**/Под ред. А. И. Кириллова. – М.: ФИЗМАТЛИТ, 2008. – 384 с. (с.158.)

### Задача К9.1.

2

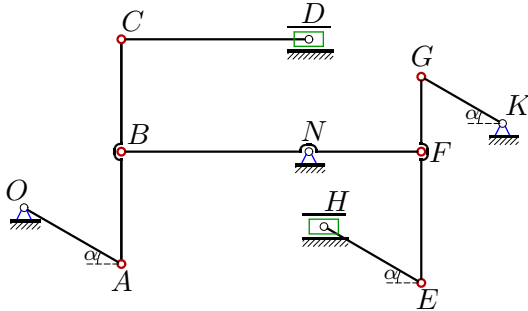

$\omega_{OA} = 3 \text{ рад/с}, \alpha = 30^\circ,$   
 $AB = 30, BC = 30,$   
 $NB = 50, NF = 30,$   
 $CD = 50, EH = 30,$   
 $FE = 35, FG = 20,$   
 $OA = 30, KG = 25.$   
 $a_A, a_B, a_C - ?$

### Задача К9.2.

2

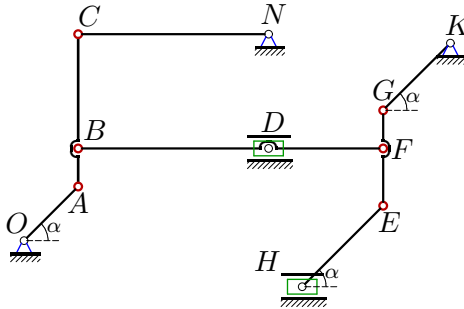

$\omega_{NC} = 1 \text{ рад/с}, \alpha = 45^\circ,$   
 $AB = 10, BC = 30,$   
 $DB = 50, DF = 30,$   
 $NC = 50, EH = 30,$   
 $FE = 15, FG = 10,$   
 $OA = 20, KG = 25.$   
 $a_A, a_B, a_C - ?$

### Задача К9.3.

2

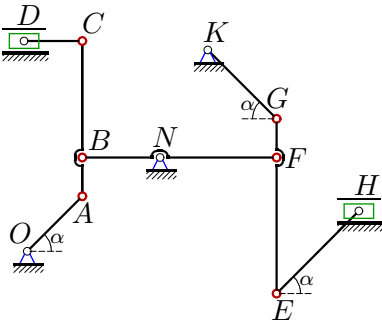

$\omega_{OA} = 1 \text{ рад/с}, \alpha = 45^\circ,$   
 $AB = 10, BC = 30,$   
 $NB = 20, NF = 30,$   
 $CD = 15, EH = 30,$   
 $FE = 35, FG = 10,$   
 $OA = 20, KG = 25.$   
 $a_A, a_B, a_C - ?$

### Задача К9.4.

2

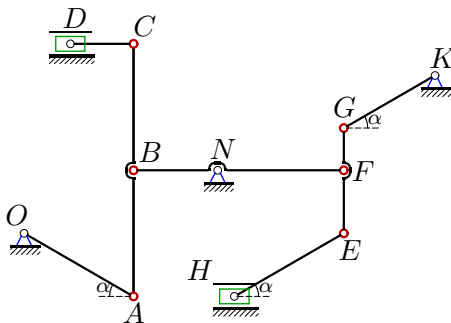

$\omega_{KG} = 4 \text{ рад/с}, \alpha = 30^\circ,$   
 $AB = 30, BC = 30,$   
 $NB = 20, NF = 30,$   
 $CD = 15, EH = 30,$   
 $FE = 15, FG = 10,$   
 $OA = 30, KG = 25.$   
 $a_G, a_F, a_E - ?$

**Задача K9.5.**

2

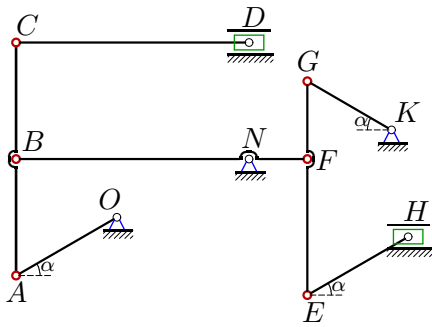

$\omega_{KG} = 2 \text{ рад/с}, \alpha = 30^\circ,$   
 $AB = 30, BC = 30,$   
 $NB = 60, NF = 15,$   
 $CD = 60, EH = 30,$   
 $FE = 35, FG = 20,$   
 $OA = 30, KG = 25.$   
 $a_G, a_F, a_E - ?$

**Задача K9.6.**

2

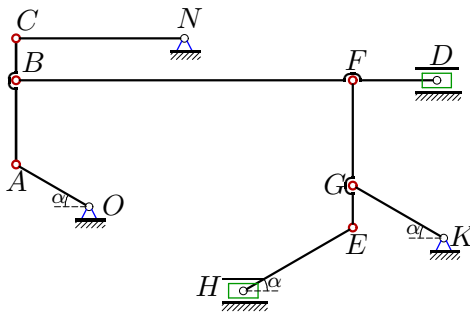

$\omega_{OA} = 2 \text{ рад/с}, \alpha = 30^\circ,$   
 $AB = 20, BC = 10,$   
 $BF = 80, FD = 20,$   
 $NC = 40, EH = 30,$   
 $FE = 35, FG = 25,$   
 $OA = 20, KG = 25.$   
 $a_A, a_B, a_C - ?$

**Задача K9.7.**

2

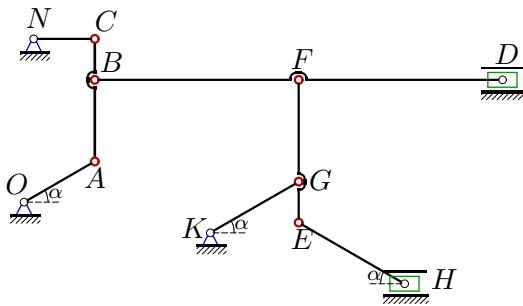

$\omega_{NC} = 3 \text{ рад/с}, \alpha = 30^\circ,$   
 $AB = 20, BC = 10,$   
 $BF = 50, FD = 50,$   
 $NC = 15, EH = 30,$   
 $FE = 35, FG = 25,$   
 $OA = 20, KG = 25.$   
 $a_A, a_B, a_C - ?$

**Задача K9.8.**

2

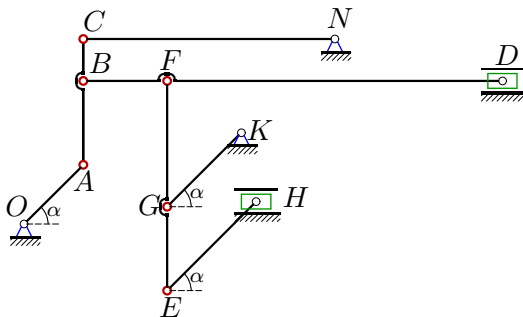

$\omega_{NC} = 4 \text{ рад/с}, \alpha = 45^\circ,$   
 $AB = 20, BC = 10,$   
 $BF = 20, FD = 80,$   
 $NC = 60, EH = 30,$   
 $FE = 50, FG = 30,$   
 $OA = 20, KG = 25.$   
 $a_A, a_B, a_C - ?$

**Задача K9.9.**

2

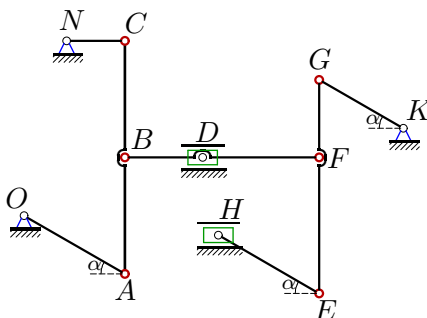

$\omega_{NC} = 3 \text{ рад/с}, \alpha = 30^\circ,$   
 $AB = 30, BC = 30,$   
 $DB = 20, DF = 30,$   
 $NC = 15, EH = 30,$   
 $FE = 35, FG = 20,$   
 $OA = 30, KG = 25.$   
 $a_A, a_B, a_C - ?$

**Задача K9.10.**

2

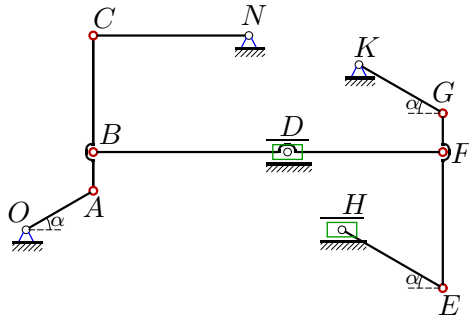

$\omega_{OA} = 1 \text{ рад/с}, \alpha = 30^\circ,$   
 $AB = 10, BC = 30,$   
 $DB = 50, DF = 40,$   
 $NC = 40, EH = 30,$   
 $FE = 35, FG = 10,$   
 $OA = 20, KG = 25.$   
 $a_A, a_B, a_C - ?$

**Задача K9.11.**

2

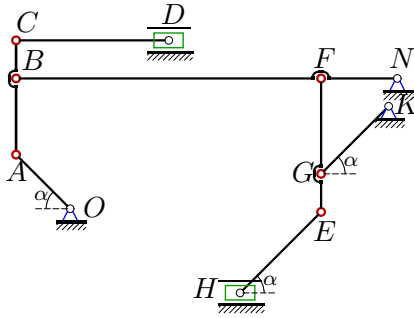

$\omega_{OA} = 3 \text{ рад/с}, \alpha = 45^\circ,$   
 $AB = 20, BC = 10,$   
 $BF = 80, NF = 20,$   
 $CD = 40, EH = 30,$   
 $FG = 25, GE = 10,$   
 $OA = 20, KG = 25.$   
 $a_A, a_B, a_C - ?$

**Задача K9.12.**

2

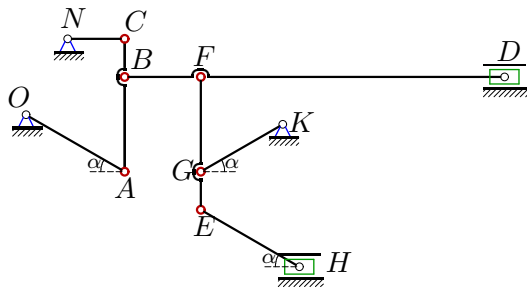

$\omega_{NC} = 2 \text{ рад/с}, \alpha = 30^\circ,$   
 $AB = 25, BC = 10,$   
 $BF = 20, FD = 80,$   
 $NC = 15, EH = 30,$   
 $FE = 35, FG = 25,$   
 $OA = 30, KG = 25.$   
 $a_A, a_B, a_C - ?$

**Задача K9.13.**

2

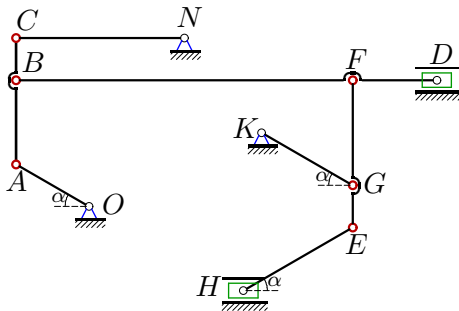

$\omega_{OA} = 2 \text{ рад/с}, \alpha = 30^\circ,$   
 $AB = 20, BC = 10,$   
 $BF = 80, FD = 20,$   
 $NC = 40, EH = 30,$   
 $FE = 35, FG = 25,$   
 $OA = 20, KG = 25.$   
 $a_A, a_B, a_C - ?$

**Задача K9.14.**

2

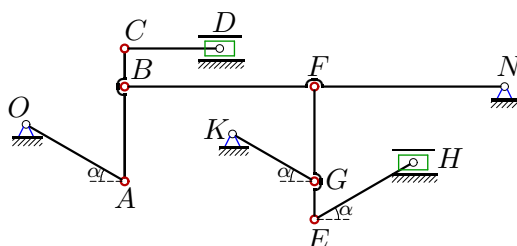

$\omega_{OA} = 2 \text{ рад/с}, \alpha = 30^\circ,$   
 $AB = 25, BC = 10,$   
 $BF = 50, NF = 50,$   
 $CD = 25, EH = 30,$   
 $FG = 25, GE = 10,$   
 $OA = 30, KG = 25.$   
 $a_A, a_B, a_C - ?$

Задача K9.15.

2

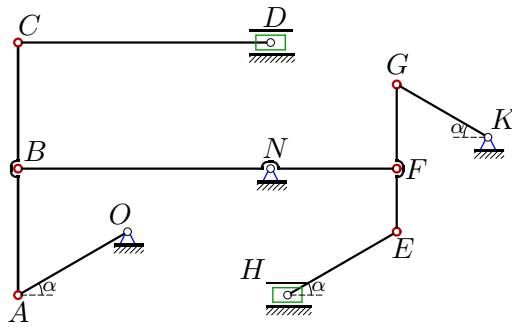

$\omega_{OA} = 1$  рад/с,  $\alpha = 30^\circ$ ,  
 $AB = 30$ ,  $BC = 30$ ,  
 $NB = 60$ ,  $NF = 30$ ,  
 $CD = 60$ ,  $EH = 30$ ,  
 $FE = 15$ ,  $FG = 20$ ,  
 $OA = 30$ ,  $KG = 25$ .  
 $a_A$ ,  $a_B$ ,  $a_C$  - ?

Задача K9.16.

2

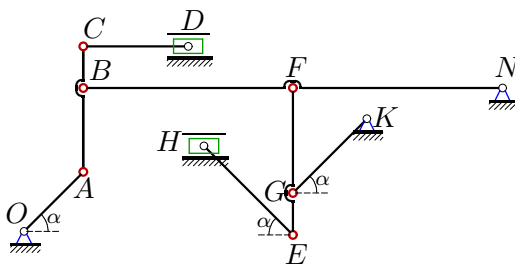

$\omega_{NB} = 4$  рад/с,  $\alpha = 45^\circ$ ,  
 $AB = 20$ ,  $BC = 10$ ,  
 $BF = 50$ ,  $NF = 50$ ,  
 $CD = 25$ ,  $EH = 30$ ,  
 $FG = 25$ ,  $GE = 10$ ,  
 $OA = 20$ ,  $KG = 25$ .  
 $a_A$ ,  $a_B$ ,  $a_C$  - ?

Задача K9.17.

2

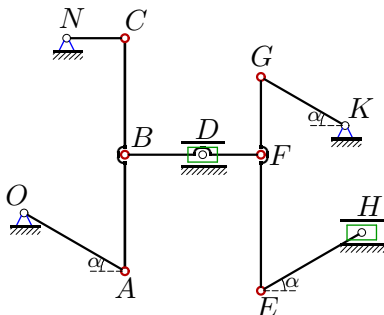

$\omega_{NC} = 2$  рад/с,  $\alpha = 30^\circ$ ,  
 $AB = 30$ ,  $BC = 30$ ,  
 $DB = 20$ ,  $DF = 15$ ,  
 $NC = 15$ ,  $EH = 30$ ,  
 $FE = 35$ ,  $FG = 20$ ,  
 $OA = 30$ ,  $KG = 25$ .  
 $a_A$ ,  $a_B$ ,  $a_C$  - ?

Задача K9.18.

2

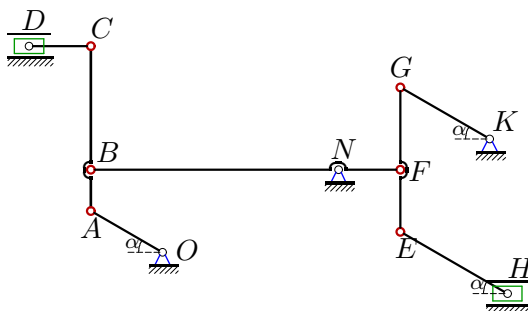

$\omega_{BF} = 4$  рад/с,  $\alpha = 30^\circ$ ,  
 $AB = 10$ ,  $BC = 30$ ,  
 $NB = 60$ ,  $NF = 15$ ,  
 $CD = 15$ ,  $EH = 30$ ,  
 $FE = 15$ ,  $FG = 20$ ,  
 $OA = 20$ ,  $KG = 25$ .  
 $a_A$ ,  $a_B$ ,  $a_C$  - ?

Задача K9.19.

2

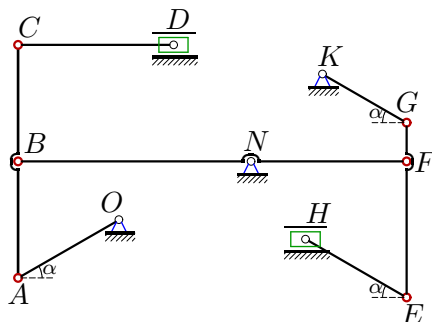

$\omega_{KG} = 3$  рад/с,  $\alpha = 30^\circ$ ,  
 $AB = 30$ ,  $BC = 30$ ,  
 $NB = 60$ ,  $NF = 40$ ,  
 $CD = 40$ ,  $EH = 30$ ,  
 $FE = 35$ ,  $FG = 10$ ,  
 $OA = 30$ ,  $KG = 25$ .  
 $a_G$ ,  $a_F$ ,  $a_E$  - ?

Задача K9.20.

2

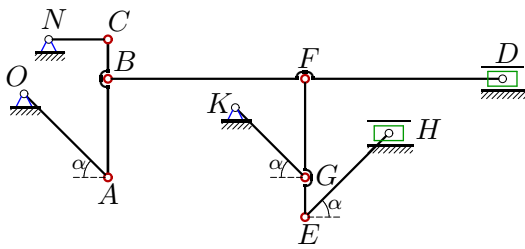

$\omega_{NC} = 3$  рад/с,  $\alpha = 45^\circ$ ,  
 $AB = 25$ ,  $BC = 10$ ,  
 $BF = 50$ ,  $FD = 50$ ,  
 $NC = 15$ ,  $EH = 30$ ,  
 $FE = 35$ ,  $FG = 25$ ,  
 $OA = 30$ ,  $KG = 25$ .  
 $a_A$ ,  $a_B$ ,  $a_C$  - ?

Задача K9.21.

2

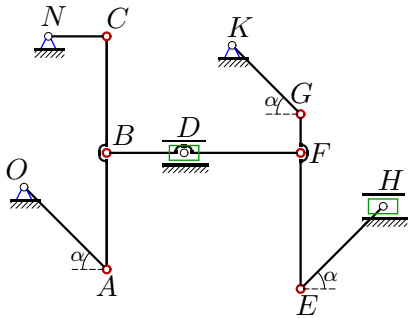

$\omega_{OA} = 3$  рад/с,  $\alpha = 45^\circ$ ,  
 $AB = 30$ ,  $BC = 30$ ,  
 $DB = 20$ ,  $DF = 30$ ,  
 $NC = 15$ ,  $EH = 30$ ,  
 $FE = 35$ ,  $FG = 10$ ,  
 $OA = 30$ ,  $KG = 25$ .  
 $a_A$ ,  $a_B$ ,  $a_C$  - ?

Задача K9.22.

2

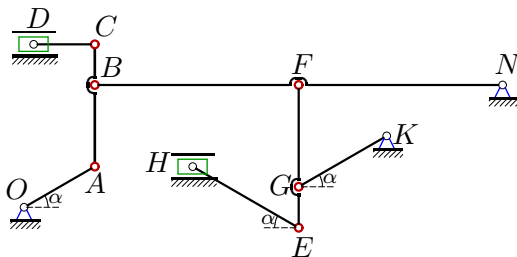

$\omega_{KG} = 2$  рад/с,  $\alpha = 30^\circ$ ,  
 $AB = 20$ ,  $BC = 10$ ,  
 $BF = 50$ ,  $NF = 50$ ,  
 $CD = 15$ ,  $EH = 30$ ,  
 $FG = 25$ ,  $GE = 10$ ,  
 $OA = 20$ ,  $KG = 25$ .  
 $a_G$ ,  $a_F$ ,  $a_E$  - ?

Задача K9.23.

2

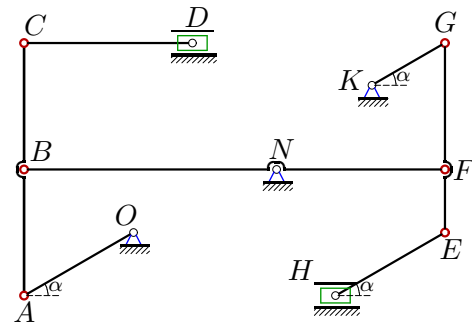

$\omega_{BF} = 4$  рад/с,  $\alpha = 30^\circ$ ,  
 $AB = 30$ ,  $BC = 30$ ,  
 $NB = 60$ ,  $NF = 40$ ,  
 $CD = 40$ ,  $EH = 30$ ,  
 $FE = 15$ ,  $FG = 30$ ,  
 $OA = 30$ ,  $KG = 20$ .  
 $a_A$ ,  $a_B$ ,  $a_C$  - ?

Задача K9.24.

2

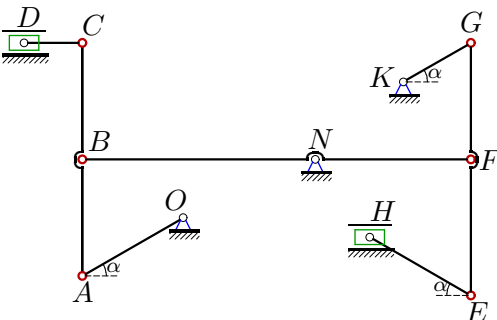

$\omega_{BF} = 1$  рад/с,  $\alpha = 30^\circ$ ,  
 $AB = 30$ ,  $BC = 30$ ,  
 $NB = 60$ ,  $NF = 40$ ,  
 $CD = 15$ ,  $EH = 30$ ,  
 $FE = 35$ ,  $FG = 30$ ,  
 $OA = 30$ ,  $KG = 20$ .  
 $a_A$ ,  $a_B$ ,  $a_C$  - ?

Задача K9.25.

2

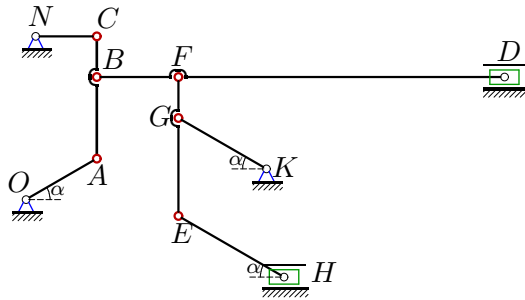

$\omega_{OA} = 1$  рад/с,  $\alpha = 30^\circ$ ,  
 $AB = 20$ ,  $BC = 10$ ,  
 $BF = 20$ ,  $FD = 80$ ,  
 $NC = 15$ ,  $EH = 30$ ,  
 $FE = 34$ ,  $FG = 10$ ,  
 $OA = 20$ ,  $KG = 25$ .  
 $a_A, a_B, a_C - ?$

Задача K9.26.

2

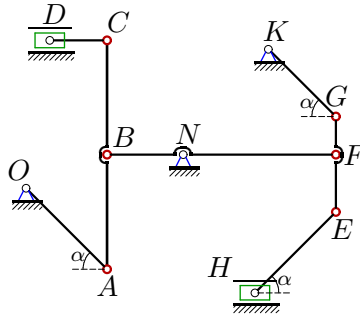

$\omega_{BF} = 2$  рад/с,  $\alpha = 45^\circ$ ,  
 $AB = 30$ ,  $BC = 30$ ,  
 $NB = 20$ ,  $NF = 40$ ,  
 $CD = 15$ ,  $EH = 30$ ,  
 $FE = 15$ ,  $FG = 10$ ,  
 $OA = 30$ ,  $KG = 25$ .  
 $a_A, a_B, a_C - ?$

Задача K9.27.

2

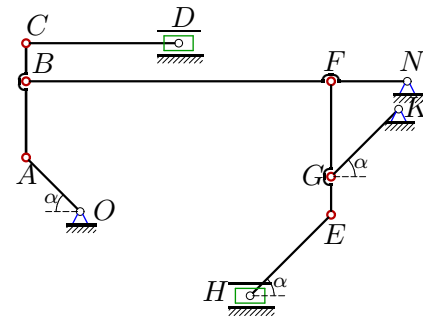

$\omega_{KG} = 4$  рад/с,  $\alpha = 45^\circ$ ,  
 $AB = 20$ ,  $BC = 10$ ,  
 $BF = 80$ ,  $NF = 20$ ,  
 $CD = 40$ ,  $EH = 30$ ,  
 $FG = 25$ ,  $GE = 10$ ,  
 $OA = 20$ ,  $KG = 25$ .  
 $a_G, a_F, a_E - ?$

Задача K9.28.

2

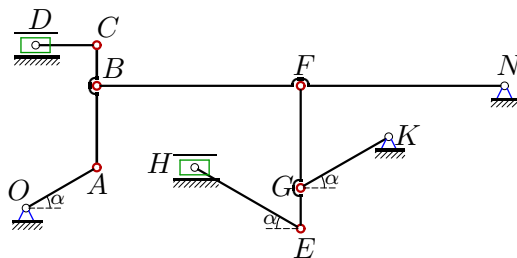

$\omega_{KG} = 4$  рад/с,  $\alpha = 30^\circ$ ,  
 $AB = 20$ ,  $BC = 10$ ,  
 $BF = 50$ ,  $NF = 50$ ,  
 $CD = 15$ ,  $EH = 30$ ,  
 $FG = 25$ ,  $GE = 10$ ,  
 $OA = 20$ ,  $KG = 25$ .  
 $a_G, a_F, a_E - ?$

Задача K9.29.

2

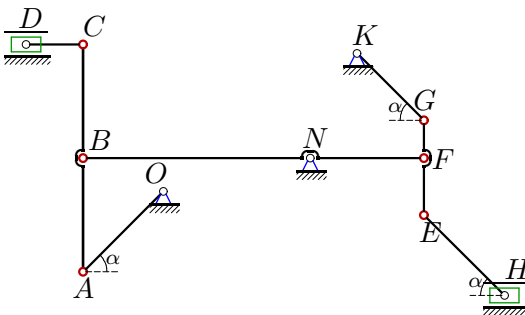

$\omega_{BF} = 1$  рад/с,  $\alpha = 45^\circ$ ,  
 $AB = 30$ ,  $BC = 30$ ,  
 $NB = 60$ ,  $NF = 30$ ,  
 $CD = 15$ ,  $EH = 30$ ,  
 $FE = 15$ ,  $FG = 10$ ,  
 $OA = 30$ ,  $KG = 25$ .  
 $a_A, a_B, a_C - ?$

Задача К9.30.

2

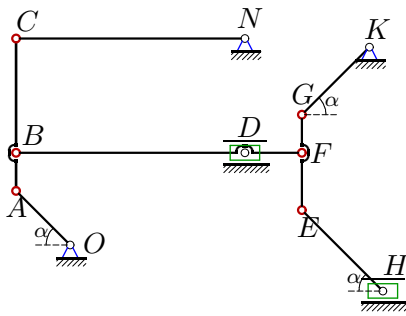

$\omega_{OA} = 4 \text{ рад/с}, \alpha = 45^\circ,$   
 $AB = 10, BC = 30,$   
 $DB = 60, DF = 15,$   
 $NC = 60, EH = 30,$   
 $FE = 15, FG = 10,$   
 $OA = 20, KG = 25.$   
 $a_A, a_B, a_C - ?$

**К9 Ответы.**  
**Кинематический анализ механизма (7 звеньев)**

04.04.2012

№	$v_A$	$v_B$	$v_C$	$v_D$	$v_E$	$v_F$	$v_G$	$v_H$
1	90.000	77.942	90.000	45.000	66.480	46.765	54.000	74.250
2	70.711	62.500	50.000	37.500	141.956	48.023	42.426	168.750
3	20.000	14.142	44.721	42.426	77.217	21.213	30.000	53.033
4	66.667	57.735	66.667	33.333	114.564	86.603	100.000	125.000
5	200.000	173.205	200.000	100.000	61.555	43.301	50.000	18.750
6	40.000	35.277	34.641	6.667	7.524	9.615	8.000	6.933
7	51.962	45.826	45.000	8.660	26.889	24.109	25.981	27.713
8	339.411	252.982	240.000	80.000	328.596	208.000	271.529	74.667
9	51.962	46.837	45.000	12.990	123.920	68.739	77.942	142.894
10	20.000	18.875	17.321	7.500	15.002	15.756	16.000	2.250
11	60.000	42.426	47.434	21.213	14.599	8.485	12.000	3.394
12	34.641	30.405	30.000	4.949	32.141	24.505	27.713	35.235
13	40.000	35.277	34.641	6.667	7.524	9.615	8.000	6.933
14	60.000	51.962	53.329	12.000	33.407	25.981	30.000	36.000
15	30.000	25.981	30.000	15.000	14.156	12.990	15.000	1.875
16	565.685	400.000	447.214	200.000	344.093	200.000	282.843	480.000
17	34.641	31.225	30.000	8.660	51.702	24.109	25.981	33.558
18	277.128	240.000	480.000	415.692	65.383	60.000	69.282	60.622
19	112.500	97.428	112.500	56.250	146.442	64.952	75.000	168.750
20	63.640	46.801	45.000	12.857	34.655	25.914	31.820	48.857
21	90.000	71.151	63.640	31.820	486.749	100.623	135.000	381.838
22	100.000	86.603	90.139	25.000	55.678	43.301	50.000	60.000
23	277.128	240.000	277.128	138.564	166.533	160.000	184.752	138.564
24	69.282	60.000	69.282	34.641	48.228	40.000	46.188	3.849
25	20.000	17.638	17.321	3.333	37.829	14.252	16.000	27.200
26	56.569	40.000	56.569	40.000	144.222	80.000	113.137	40.000
27	500.000	353.553	395.285	176.777	121.655	70.711	100.000	28.284
28	200.000	173.205	180.278	50.000	111.355	86.603	100.000	120.000
29	84.853	60.000	84.853	60.000	54.083	30.000	42.426	75.000
30	80.000	70.711	56.569	42.426	86.023	44.721	20.000	98.995

$N_0$	$\omega_{OA}$	$\omega_{CA}$	$\omega_{CD}$	$\omega_{BF}$	$\omega_{FE}$	$\omega_{KG}$	$\omega_{EH}$	$\omega_{NC}$	$a_A$	$a_B$	$a_C$	$a_E$	$a_F$	$a_G$
1	3.000	1.500	-1.559	-1.559	1.350	2.160	-1.800	-	2.700	1.390	4.768	-	-	-
2	-3.536	1.250	-	1.000	6.750	-1.697	1.414	1.000	4.207	3.032	0.500	-	-	-
3	1.000	-1.414	0.943	-0.707	2.121	-1.200	1.000	-	0.200	0.356	1.251	-	-	-
4	2.222	1.111	3.849	-2.887	-5.000	4.000	-3.333	-	-	-	-	14.109	5.148	4.000
5	-6.667	-3.333	-2.887	-2.887	1.250	2.000	1.667	-	-	-	-	4.966	1.264	1.000
6	2.000	-0.667	-	0.346	0.107	0.320	-0.267	0.866	0.800	0.652	0.612	-	-	-
7	2.598	-0.866	-	-0.450	-0.173	1.039	-0.866	3.000	1.704	1.465	1.350	-	-	-
8	-16.971	8.000	-	2.400	3.733	10.861	9.051	4.000	102.473	27.897	9.600	-	-	-
9	1.732	0.433	-	-2.250	2.598	3.118	-2.598	3.000	0.981	1.163	1.350	-	-	-
10	1.000	-0.250	-	-0.346	0.050	-0.640	-0.533	-0.433	0.200	0.154	0.146	-	-	-
11	3.000	-2.121	1.061	0.424	0.339	0.480	-0.400	-	1.800	2.180	2.648	-	-	-
12	1.155	0.495	-	-0.300	-0.752	-1.109	-0.924	2.000	0.421	0.547	0.600	-	-	-
13	2.000	-0.667	-	0.346	0.107	-0.320	-0.267	0.866	0.800	0.652	0.612	-	-	-
14	2.000	1.200	-2.078	-0.520	0.600	1.200	-1.000	-	1.200	0.361	0.799	-	-	-
15	1.000	0.500	0.433	0.433	-0.375	-0.600	0.500	-	0.300	0.135	0.035	-	-	-
16	-28.284	20.000	16.000	4.000	8.000	11.314	-9.428	-	316.550	16.000	181.597	-	-	-
17	1.155	0.289	-	-1.500	1.083	1.039	0.866	2.000	0.436	0.517	0.600	-	-	-
18	13.856	-13.856	-16.000	4.000	-1.732	-2.771	-2.309	-	58.657	9.600	140.251	-	-	-
19	3.750	1.875	2.436	1.624	-3.750	3.000	2.500	-	-	-	-	7.736	2.742	2.250
20	2.121	1.286	-	-0.450	0.386	1.273	-1.061	3.000	1.451	1.355	1.350	-	-	-
21	3.000	1.061	-	-3.182	12.728	-5.400	4.500	4.243	2.700	2.790	2.969	-	-	-
22	-5.000	2.500	-5.774	0.866	1.000	2.000	-1.667	-	-	-	-	1.220	0.451	1.000
23	9.238	4.619	6.000	4.000	3.079	9.238	6.158	-	26.645	9.600	9.240	-	-	-
24	2.309	1.155	-4.000	1.000	0.770	2.309	1.540	-	1.665	0.600	0.578	-	-	-
25	1.000	-0.333	-	-0.173	1.133	-0.640	-0.533	1.155	0.200	0.227	0.240	-	-	-
26	-1.886	-1.333	-2.667	2.000	-8.000	4.525	3.771	-	1.111	0.800	2.630	-	-	-
27	25.000	-17.678	8.839	3.536	2.828	4.000	-3.333	-	-	-	-	4.683	2.634	4.000
28	-10.000	5.000	-11.547	1.732	2.000	4.000	-3.333	-	-	-	-	4.881	1.803	4.000
29	2.828	2.000	-4.000	1.000	-3.000	1.697	-1.414	-	2.501	0.600	1.558	-	-	-
30	4.000	-1.414	-	0.943	-2.828	-0.800	-0.667	0.943	3.200	3.068	3.109	-	-	-